

# HELIOSHADE<sup>®</sup>

RUBIX CASSETTE



HELIOSHADE  
COLOUR DESIGN

*over 120 standard  
frame colours*



 BEAUFORT WIND SCALE

Rated up to Category 5

 5 YEAR WARRANTY

 **helioscreen**<sup>®</sup>  
Intelligent Sun Control Solutions<sup>®</sup>

# HELIOSHADE® RUBIX CASSETTE

## SEAMLESS INTEGRATION FOR MODERN ARCHITECTURE

The latest addition to the Helioscreen collection, the **Rubix Cassette** awning offers a premium shading solution with a focus on clean lines to suit the finest architecture. Designed to integrate seamlessly, the Rubix Full Cassette offers a streamlined architectural finish along with full protection to the system and fabric when not in use. Utilising the highest quality materials available including chromatised aluminium, Dulux powdercoating finishes, high grade stainless steel screws, along with precision engineering and design down to the last detail, ensures long lasting durability and functionality for many years.



Tested and proven to well over 70,000 full cycles, the Multiflex 4-cable arm system is the strongest of it's kind on the market. With daily use this is more than a 200 year life span.

Ideally suited to our harsh Australian conditions, the arm system is optimised for long lasting tautness of the fabric under extended heavy use.

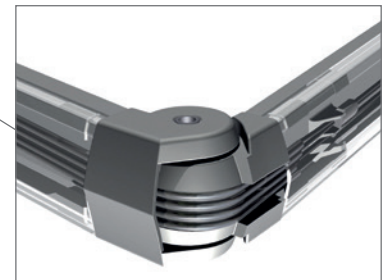

### STRONG ARMS – THE HEART OF THE AWNING

The **Rubix Cassette** arm is characterised by its elegant, eye-catching design and convincing performance. All components have been developed to ensure smooth functioning and high durability, which have proved themselves in very demanding load tests. The use of high-quality aluminium profiles in combination with high-strength cast and drop-forged components stand for optimal safety even under extreme load. The specially developed Multiflex power band is made up of four tear-resistant steel cables sheathed in a highly flexible plastic material protecting against corrosion. It applies the force of spring movements in the arm sections and ensures proper tensioning of the awning, whilst still allowing flexibility during gusts of wind.



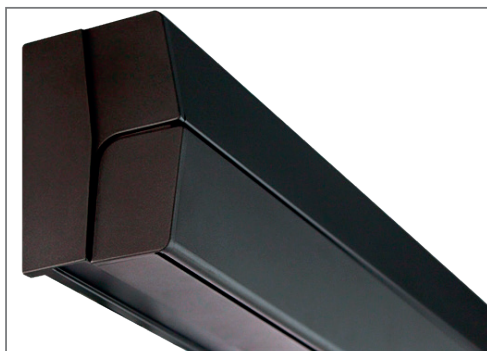

#### SYSTEM DETAILS

#### RUBIX CASSETTE

Max width	6,000mm
Max projection	3,500mm
Installation angle	5-40°
Standard operation	Motor (gear unit & hand crank possible)
Fabric colours	Over 100 fabric colours
Frame colours	Over 120 Dulux & custom powdercoat colours

#### THE CASSETTE

The slimline Rubix Cassette with colour matched end caps in cast aluminium offers the perfect protection from the elements all with a size of just 154x212mm.

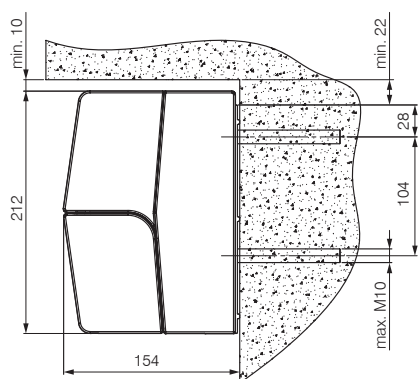

Wall/face mounting

(dimensions in mm)

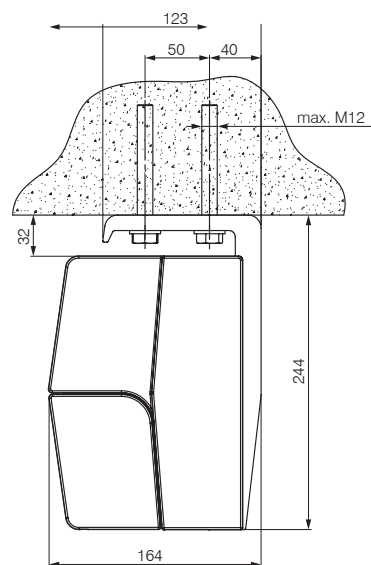

Ceiling/top mounting





# HELIOSHADE® AWNINGS

## UNMATCHED PERFORMANCE FOR COMMERCIAL APPLICATIONS

The Helioscreen team have a proven reputation for outstanding performance when it comes to commercial awning projects. Offering an extensive range of products with local support and next generation solutions for over a quarter of a century is why Helioscreen as a company is synonymous with quality and high-caliber service across Australia and New Zealand.

Using only the finest materials available from around the world each component is selected to exceed expectations. When coupled with precision engineering, innovation and the latest in advanced technology, Helioscreen awning systems have clearly proven to withstand the test of time.

Local assembly ensures precision results are made to order, and offers efficient turnaround times for production and after-market service. Production of our custom made textiles is done in-house with the latest innovative technology and we offer a choice of over 120 Dulux powdercoat colours at no extra charge. This guarantees the best aesthetic results for each system. Furthermore, commercial grade powdercoating is also available for prestigious projects.

Used nationwide in landmark hospitality venues including bars, restaurants, hotels, clubs and renowned commercial buildings,

the Helioscreen range has been the selection of choice for many of Australia's leading architects, designers and builders over the past 25 years. Other commercial applications can be found at shopping centres, airports, apartment complexes, resorts, marinas, libraries, museums and universities.

Working to set new standards across our industry in functionality, performance and design, provides us with the opportunity to incorporate our intelligent sun control solutions towards long term sustainability by reducing energy consumption and contributing to an environmentally greener future.

### Helioshade® external projects include:

Westfield Shopping Centre's, Coke-a-Cola Sydney, Melbourne Blood Bank, Cockel Bay Wharf, Jaguar Motors, Bupa Health, Toowoomba Shopping Centre, Barossa Valley Vineyards, Sydney University, Jones Bay Wharf, Audi Sydney, Virgin Lounge, Newcastle Hospital, Hastings St Noosa, St Josephs College Brisbane, Austereo Melbourne, Salthouse Cairns, Toyota Adelaide, Perth Library, Woolloomooloo Finger Wharf, Top Ryde Shopping Centre, Melbourne Rowing Club, Adelaide Oval, Northgate Hobart, VW, Darling Island Apartments, Stocklands and Harley Davidson.



### HELIOSCREEN'S INDOOR AND OUTDOOR RANGE

-  90% Reduced Heat Radiation
-  Windsensor Retractor
-  5 Year Warranty
-  Powered by Somfy 5-year motor warranty

Includes: Roller Blinds, Roman Blinds, Panel Glides, Blackouts, External Screens, Awnings, External Venetians, and Retractable Roof Systems.



Scan QR code for more info

**Helioscreen Australia Pty Ltd – Dealers Australia Wide**

[www.helioscreen.com.au](http://www.helioscreen.com.au) | [enquiries@helioscreen.com.au](mailto:enquiries@helioscreen.com.au) | Phone 1300 766 319

 **helioscreen**  
Intelligent Sun Control Solutions®